

HandPunch 2000

Manual

 **Recognition Systems.**

1520 Dell Ave.
Campbell, CA 95008

Technical Operations: 408-341-4110
RSI Main: 408-341-4100
RSI Main Fax: 408-341-4101
Web: www.handreader.com
P/N: 70100-6007 Version 3.0

This equipment has been tested and found to comply with the limits for a Class B digital device, pursuant to part 15 of the FCC Rules. These limits are designed to provide reasonable protection against harmful interference when the equipment is operated in a commercial environment. This equipment generates, uses, and can radiate radio frequency energy, and, if not installed and used in accordance with the Installation Manual, may cause harmful interference to radio communications. Operation of this equipment in a residential area is likely to cause harmful interference, in which case the user will be required to correct the interference at the user's own expense.

This Class A digital apparatus meets all requirements of the Canadian Interference-Causing Equipment Regulations.

Cet appareil numérique de la classe A respecte toutes les exigences du Règlement sur le matériel brouilleur du Canada.

© 1998 through 2003 Recognition Systems, Inc. – ALL RIGHTS RESERVED
Document Part Number: 70100-6007 – Revision 3 – July, 2003

HandPunch is a trademark of Recognition Systems, Inc.

The trademarks used in this Manual are the property of the trademark holders. The use of these trademarks in this Manual should not be regarded as infringing upon or affecting the validity of any of these trademarks.

Recognition Systems, Inc. reserves the right to change, without notice, product offerings or specifications.

No part of this publication may be reproduced in any form without the express written permission from Recognition Systems, Inc.

Table of Contents

Introduction 3

- Biometrics 3
- Principle of Operation 4
- Specifications 6

Planning an Installation 9

- Site Preparation 9
- HandPunch Placement 9

Wiring 10

- Power Input 10
- Battery Backup Operation 10
- HandPunch to Host Computer Connection 11
- RS-232 Host Computer Connection 11
- Modem Host Computer Connection 11

Mechanical Installation 13

- Wall Plate Installation 13

Wiring Connections 17

Erasing the Memory 21

Closing the HandPunch 23

Enter Command Menu 25

- If No One is Enrolled in the HandPunch 25
- If Users are Enrolled in the HandPunch 25
- Navigating Command Menus 27

Programming the HandPunch 29

- Service Menu 32
- Setup Menu 34
- Management Menu 37
- Enrollment Menu 39
- Special Menu 43

HandPunch Maintenance 45

Appendix A - Installation Tips 47

Appendix B - Differences in Board Layout 49

Appendix C - Old Board Installation 51

Appendix D - Troubleshooting 63

Glossary 65

Limited Warranty 67

Introduction

The HandPunch HandPunch 20001000 is a member of the Recognition Systems' line of biometric hand geometry Time and Attendance Terminals¹. The HandPunch records and stores the three-dimensional shape of the human hand for comparison and identity verification. Upon verification, the HandPunch records the time, date, user ID number, and collected time and attendance data for collection by a host computer. The HandPunch can communicate with a host computer.

The HandPunch provides proof-positive employee identification combined with the sophisticated operating features one expects in a modern Time and Attendance Terminal. Because of this unique combination of capabilities, the HandPunch provides the most accurate Time and Attendance data collection terminal available. The key features of the HandPunch include:

- Two Programmable Function Keys
- Transaction Buffer
 - 5,120 event capacity
- Programmable Clock and Date Formats and Daylight Savings Switch-over

Biometrics

Biometrics is a term describing the automatic measurement and comparison of human characteristics. While its origins are ancient, the evolution of advanced scanning and microprocessor technology brought biometrics into everyday life. Electronic hand geometry technology first appeared in the 1970s. Recognition Systems Inc., founded in 1986, built the first mass-produced hand geometry readers and made biometric technology affordable for the commercial market. Today, Recognition Systems' products are in use in every imaginable application from protecting cash vaults to verifying employee attendance in hospitals.

1. For the sake of using a consistent name throughout the manual, the HandPunch 2000 terminal is referred to as the HandPunch for the remainder of this manual.

Principle of Operation

The HandPunch uses low-level infrared light, optics, and a CMOS (IC chip) camera to capture a three-dimensional image of the hand. Using advanced microprocessor technology, the HandPunch converts the image to an electronic template. It stores the template in a database with the user's ID number.

To gain punch, the user enters his or her ID number at the HandPunch's keypad or uses an external card reader. The HandPunch prompts the user to place his or her hand on the HandPunch's platen¹. The HandPunch compares the hand on the platen with the user's unique template. If the images match, the HandPunch records the transaction for processing.

The HandPunch Terminal

The HandPunch is a time and attendance terminal designed for use with time and attendance software. Refer to Figure 1-1 on page 5 when reviewing the information in this section.

The HandPunch has an integrated keypad for ID entry (see Figure 1-1). The **CLEAR** and **ENTER** keys are used for data entry and programming.

Four different features assist the user with hand placement and read verification.

1. A light emitting diode (LED) hand placement display on the HandPunch's top panel assists users with hand placement on the platen.
2. A liquid crystal display (LCD) shows operational data and programming menus.
3. "Red light/Green light" verification LEDs quickly inform users if their verification attempts were rejected or accepted.
4. An internal beeper provides audible feedback during keypad data entry and user verification.

1. The Platen is the flat surface at the base of the HandPunch (see Figure 1-1). This is where users place their hands for enrollment and verification. It has guide pins to assist positioning the fingers during use.

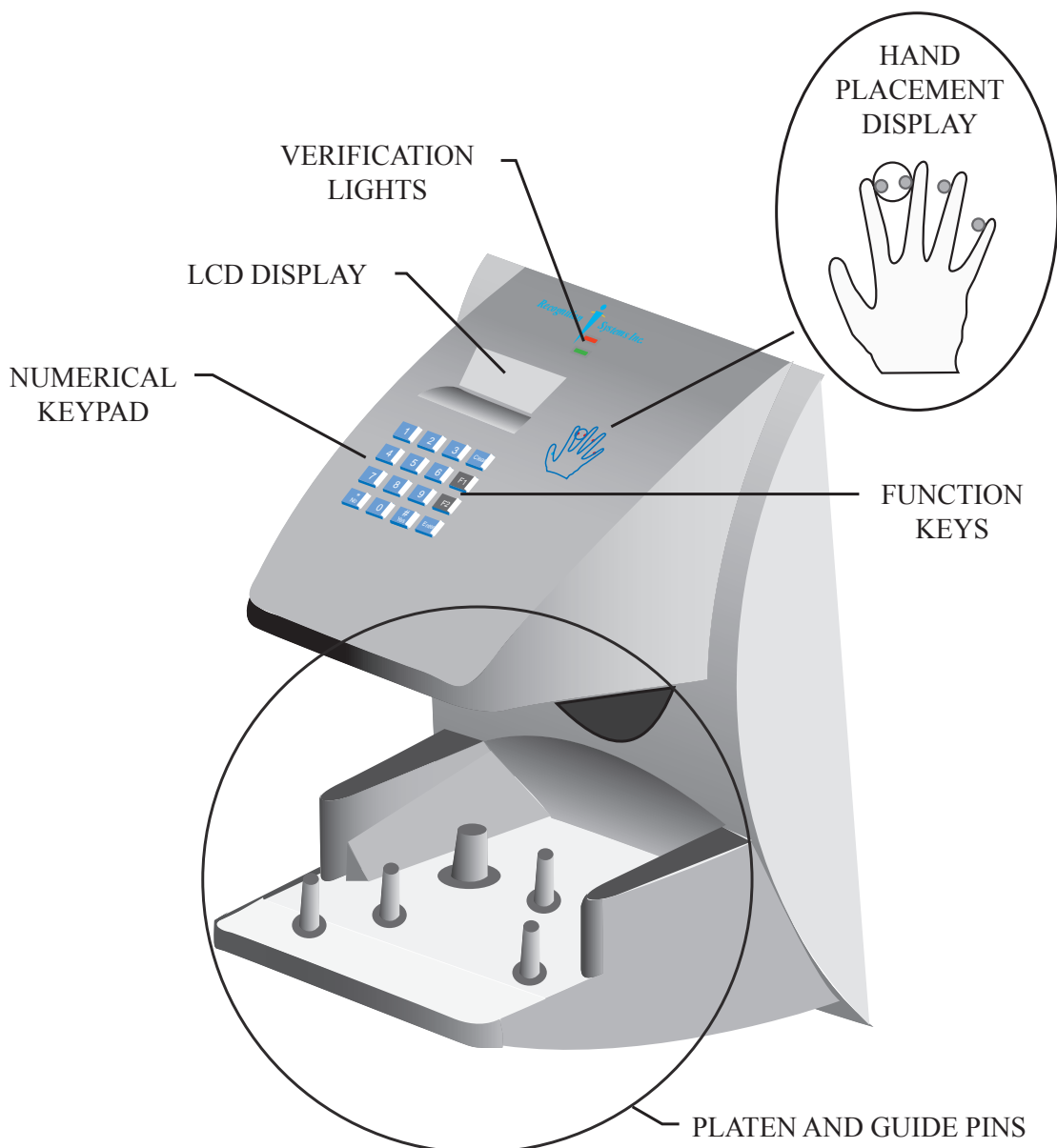

Figure 1-1: The HandPunch 2000

Specifications

Table 1: Specifications

Size:	8.85 inches wide by 11.65 inches high by 8.55 inches deep
	22.3 cm wide by 29.6 cm high by 21.7 cm deep
Power:	12 to 24 VDC or 12 to 24 VAC 50-60 Hz, 7 watts
Weight:	6 lbs (2.7 kg) – 7 lbs (3.2 kg) with optional backup battery
Temperature:	-10°C to +60°C – non-operating/storage (14°F to 140°F) 5°C to 40°C – operating (40°F to 110°F)
Relative Humidity Non-Condensing:	5% to 95% – non-operating/storage (non-condensing) 20% to 80% – operating
Verification Time:	1 second or less
Memory Retention:	5 years using a standard internal lithium battery
Transaction Buffer:	5,120 transactions
ID Number Length:	1 to 10 digits
Baud Rate:	300 to 28.8 K bps
Communications:	RS-232, optional Modem
User Capacity:	50 users
Function Keys	2 User Definable

Options

The HandPunch has the following options available.

- Backup Battery Support Rev. D See Technical Note 70200-0012 –
- Modem Communication Rev. D See Technical Note 70200-0013 –

Recommended European Power Supply:

Ault, Inc.
7300 Boone Ave. North
Minneapolis, MN 55428 USA
PH: 612-493-1900
E-mail: info@ault.com

Part number: D48-121000-A040G
230 VAC Input, 12 VDC @ 1Amp output (unregulated)
Ault style #41 connector (barrel plug)

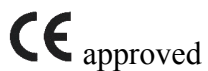

This page is intentionally blank.

Planning an Installation

Site Preparation

Before you begin installation, check the site blueprints, riser diagrams, and specifications for important information about HandPunch location and for other systems that connect to the HandPunch. Look for any existing wall preparations and wiring that other contractors may have installed for the HandPunch. A wire routing layout diagram (see Figure 3-2 on page 15) is provided to assist in planning wire routing.

HandPunch Placement

The recommended height for the HandPunch platen is 40 inches¹ (102 cm) from the finished floor. The HandPunch should be out of the path of pedestrian and vehicular traffic, and convenient to the door it is controlling. Avoid placing the HandPunch where users must cross the swing path of the door. The HandPunch should be in an area where it is not exposed to excessive airborne dust, direct sunlight, water, or chemicals.

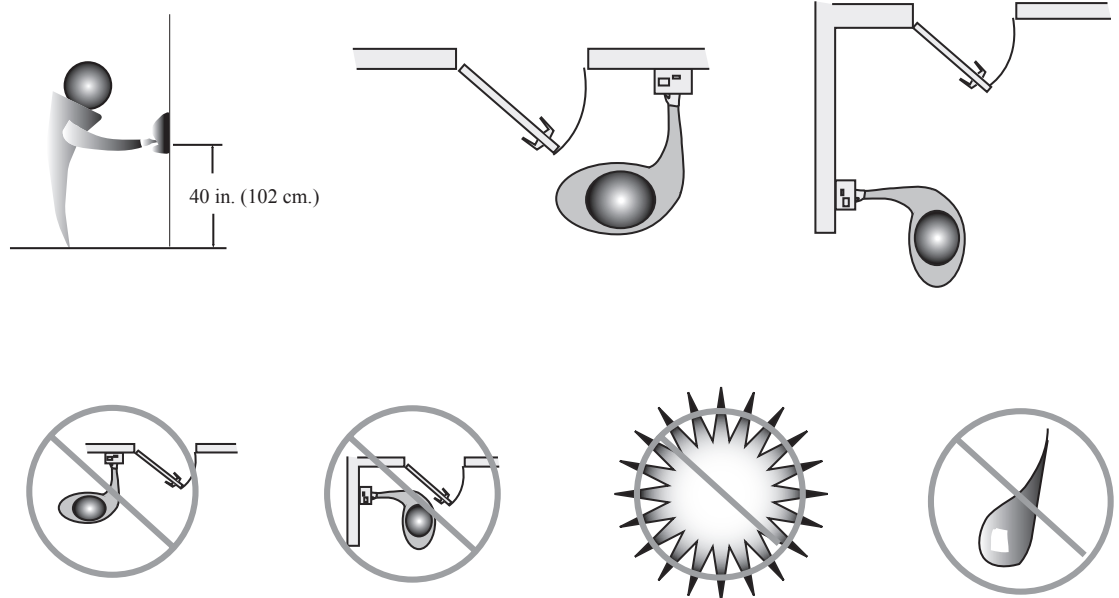

Figure 2-1: HandPunch Placement Rules

NOTE For the following sections, Recognition Systems does not supply hardware items such as power or communications wiring.

1. This height conforms to ADA standards.

Wiring

Two basic circuits typically connect to the HandPunch:

- Power Input
- HandPunch to Host Computer
 - RS-232
 - modem

The minimum wire size for these circuits is AWG 22; the maximum is AWG 18.

Power Input

The HandPunch uses an internal switching regulator to obtain internal operational power. It accepts input voltages from 12 to 24 VDC or 12 to 24 VAC at 50 to 60 Hz. The HandPunch comes with a 120 VAC to 13.5 VDC power supply (Class 2, Model No. P48131000A010G – 120 VAC, 60 Hz, 21 W, 13.5 VDC output @ 1000mA). An optional 220 VAC to 13.5 VDC power supply is also available.

To power the HandPunch with this power supply, a 120 VAC (or 220 VAC as applicable) duplex outlet must be within 5 feet of the HandPunch. The power supply has a 6-foot cable to provide a comfortable reach between power outlet and HandPunch. The barrel jack at the end of the power supply's cable is connected to J12 on the HandPunch PCB.



Do not connect a HandPunch's power supply to a switched duplex outlet. The HandPunch must have a constant source of power for proper operation.

Battery Backup Operation

An optional power-fail protection circuit board can be attached to the main circuit board to provide and control battery backup. The battery backup option uses a 12 volt 800 ma/hour sealed lead acid battery to provide backup battery power. This battery is located immediately inside the rear panel of the HandPunch and plugs into jack J4 on the keypad control circuit board located in the top of the chassis.

The design of the HandPunch's internal power supply is such that any range of the above input voltages may be used and still provide proper battery charge voltage and battery backup operation. Switch-over to battery power is automatic and occurs when the input voltage falls to approximately 10.5 volts. At that time the backup battery charger is disabled to save power, and uninterrupted operation continues on battery power.

When input power is restored, the HandPunch switches off of battery operation and the battery charger is re-enabled to recharge the battery. Battery charge voltage is set at approximately 13.65 volts, and battery charge current is limited to approximately 50 mA. A fully discharged battery requires approximately 12 hours of charge to fully recover.

Additional options installed and specific configurations within the HandPunch make it difficult to predict precisely how long battery support will last, but in

general two hours of battery operation can be expected. While operating on battery backup due to loss of main input power, the battery output voltage is constantly monitored by internal circuitry. If the battery voltage reaches approximately 9.5 volts the HandPunch automatically shuts down. This is done to prevent full exhaustion of the battery. A yellow indicator on the top panel illuminates to indicate that the HandPunch is running on battery power. This indicator turns off when main input power is restored.

Shunt J7, which is located immediately in front of the DIP switches on the main logic board (see Figure 4-1 on page 17), enables or disables battery operation on those HandPunches equipped with optional battery backup. If a HandPunch does not have the optional battery backup package installed, J7 is not used. On HandPunches equipped with the battery backup option, J7 allows service personnel a mechanism for disabling battery backup operation before removal of main input power.

To fully power down a HandPunch equipped with battery backup, remove or reposition shunt J7 so that the two pins protruding up from the main logic board are not connected to each other. This effectively opens the circuit, removing the battery from any internal circuitry. Main input power can then be removed and the HandPunch will fully shut down. Once the HandPunch has fully shut down, shunt J7 may be reinstalled.

The design of the power supply is such that main input power must be reapplied to re-enable the battery protection mechanism. If shunt J7 is not properly installed, the internal backup battery will not be charged, and in the event of a main input power loss, the HandPunch will shut down.

HandPunch to Host Computer Connection

HandPunch/host computer communications can be configured in one of two ways:

- via a direct RS-232 connection
- via an optional Modem connection

RS-232 Host Computer Connection

A direct HandPunch connection to a host computer can be made through an 4-conductor cable in an RS-232 serial configuration. A 6' or 50' cable may be purchased through RSI or a wiring diagram for the RS-232 to host computer connection is found on Table 2 on page 18

Modem Host Computer Connection

The HandPunch is also available with an optional modem module for telephone line communications between the HandPunch network and the host computer. When connecting via modem, one HandPunch terminal must be configured with the modem option. This terminal will communicate with the host computer.

To make the modem connection, a telephone jack must be installed on or in the wall behind the modem HandPunch terminal. Position the RJ-11 jack location using the template provided in this manual (see Figure 3-2 on page 15). The short black cable provided with the modem HandPunch connects the terminal to the telephone jack. Figure 4-4 on page 19 a wiring diagram for a modem to host computer connection.

Mechanical Installation

Select an installation location based on the guidelines provided in the [Planning an Installation](#) section beginning on page 9.

Wall Plate Installation

Wall Preparation

NOTE *For the following procedure protect the HandPunch from the dust and debris generated during the wall plate installation process.*

1. Remove the wall plate from the packing carton. Refer to Figure 3-1 for all wall plate references in the following section.

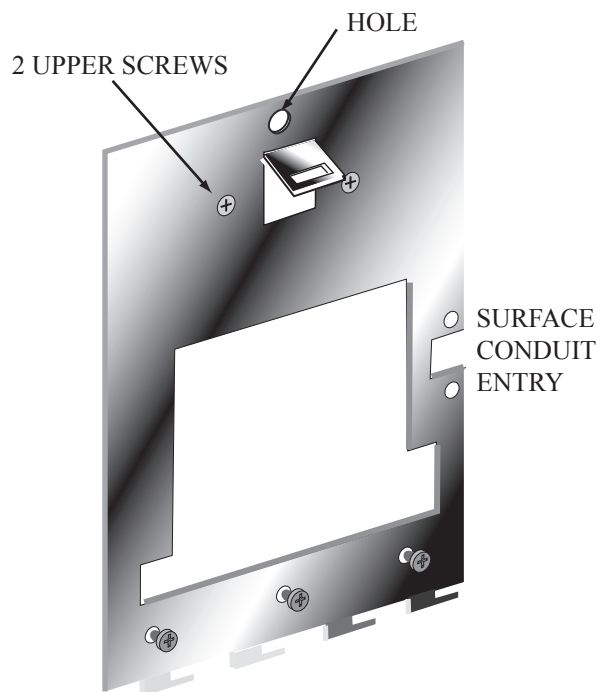

Figure 3-1: Wall Plate

2. Measure and mark a point 48 1/2 inches (123 cm) from the surface of the finished floor. This point will correspond to the Leveling Hole where the top-center point of the HandPunch should be mounted.
3. For a hollow wall, drive a small nail into the wall at the mark and hang the wall plate from the Leveling Hole located near the top of the wall plate.
4. For a solid wall, hold the wall plate against the wall, centering the Leveling Hole over the mark in the wall.

5. Align a bubble level with the top edge of the wall plate and gently rotate the wall plate until the bubble level shows that the top edge of the wall plate is level.
6. Secure the plate to the wall using heavy masking tape.
7. Using the wall plate as a template, mark the locations of the two upper screw holes and the three lower screw holes.
8. For a concealed wiring connection, trace the outline of the open area in the center of the wall plate. Identify and mark a 1/2 inch hole through which the HandPunch's wiring will be mounted.
9. For a surface conduit wiring connection, mark the two conduit clamp holes at the right side of the wall plate.
10. Remove the wall plate, masking tape, and the nail (if used).

Mounting the Wall Plate

1. For a hollow wall, use the provided hardware to mount the wall plate. Use the two auger style fasteners for the upper two mounting holes. Use the toggle bolts for the three lower mounting holes.
2. For a solid wall, use expansion bolts to mount the wall plate. For all five mounting holes, drill a 1/4 inch diameter hole, 1/4 of an inch deeper than the length of the expansion anchor.

Routing the Wiring

1. Refer to Figure 3-2 on page 15 for a template diagram to assist in routing wiring.
2. For a concealed wiring connection, drill a 1/2 inch hole in a convenient location within the open area of the wall plate. Pull the wiring to enter the HandPunch through this hole in the open area.
3. For a surface conduit wiring connection, drill a 1/4 inch diameter hole, 1/4 of an inch deeper than the length of the expansion anchor for each of the two conduit clamp holes. Route 1/2 inch, flexible conduit to the HandPunch, ending the conduit between the two conduit clamp holes. Pull the wiring to enter the HandPunch through the conduit. Pull 18 inches of wire past the end of the conduit to allow enough space for final connection to the HandPunch.
4. Clear all dust and debris away from the HandPunch mounting location.

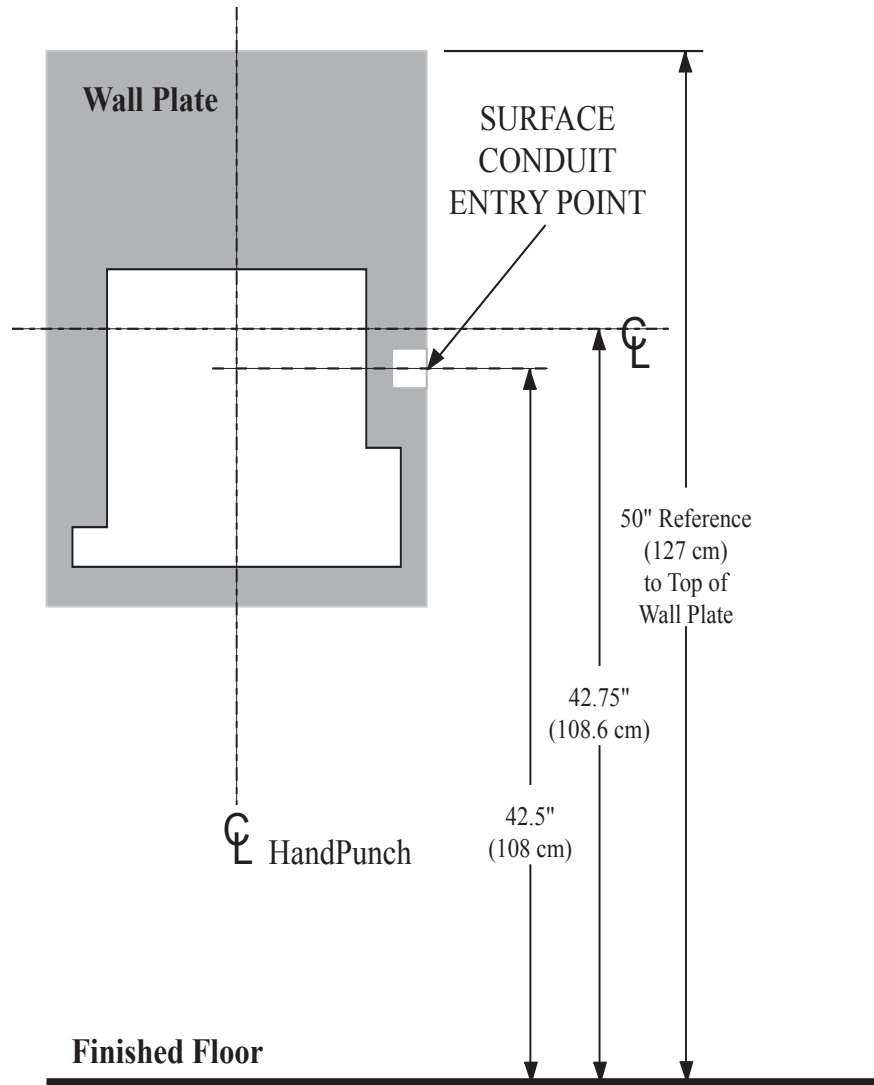

Figure 3-2: HandPunch Wire Routing Layout



Dust and debris surrounding the HandPunch can drastically affect the terminal's operation. It is important to ensure the HandPunch mounting location is free from dust and debris.

Attaching the HandPunch

1. Remove the HandPunch from its carton.
2. Align the sleeves of the back plate with the pins of the wall plate and slide the HandPunch to the left as shown in Figure X-X.

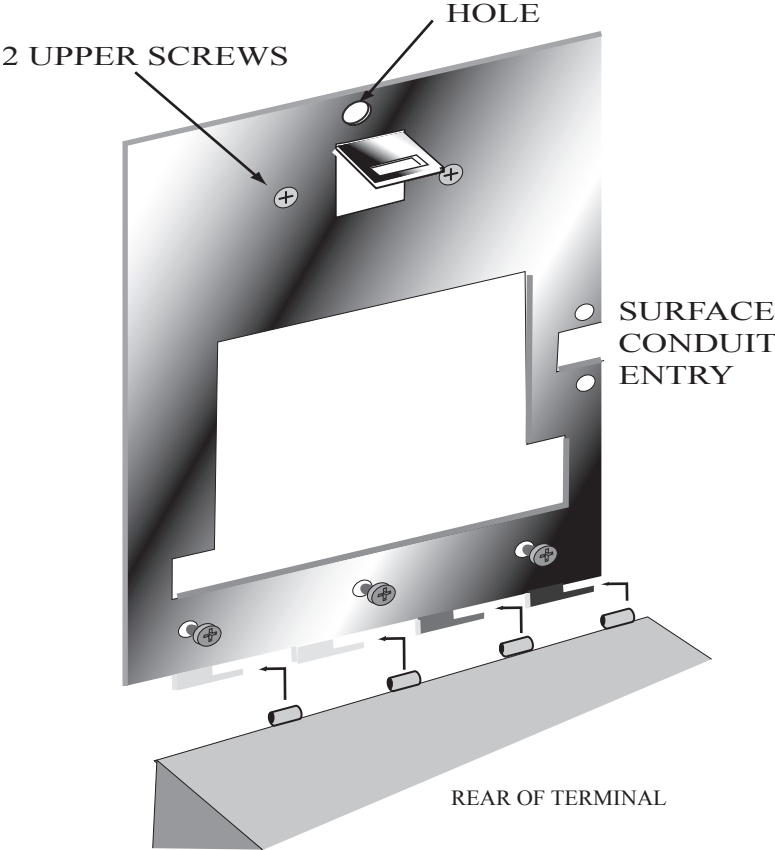

Figure 3-3: Attaching the HandPunch to the Wall Plate

Wiring Connections

Once the HandPunch is attached to the wall plate the wiring connections to the HandPunch can be made (see Figure 4-1).

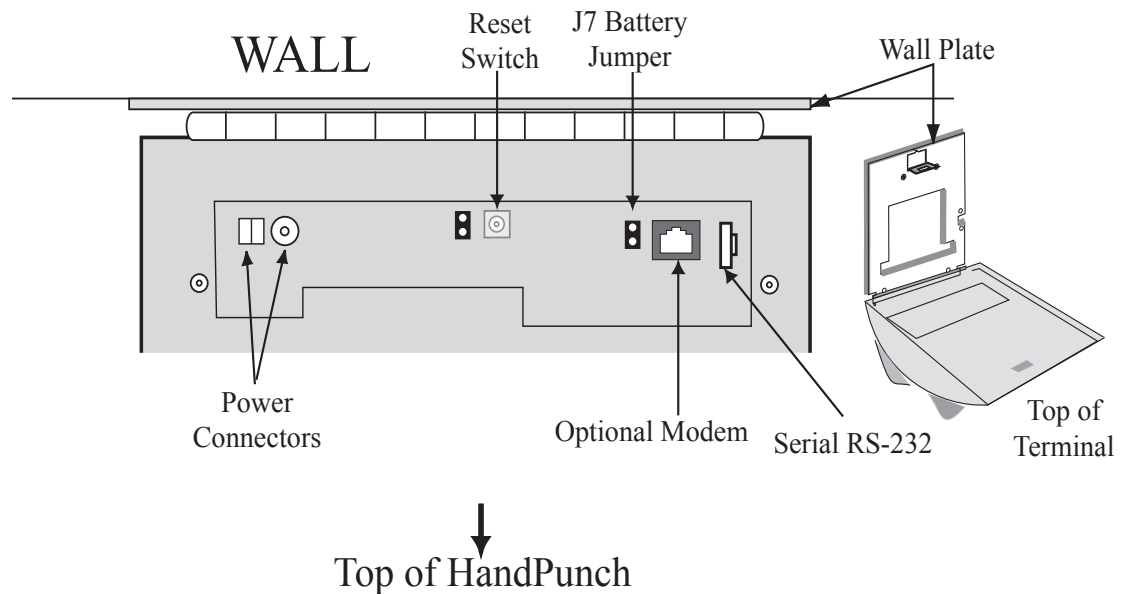

Figure 4-1: Board Layout

Wiring Examples

Table 2 on page 16 provides the pinouts for the RS-232 Serial Host Computer Connection.

Figure 4-2 on page 16 provides a diagram of the RS-232 Connector.

Figure 4-3 on page 17 provides a Serial Connection diagram

Figure 4-4 on page 17 provides a Host PC to HandPunch Modem Network wiring diagram (Modem wiring is a HandPunch option).

Table 2: RS-232 Serial Connection

J8 Pin	Signal	Connection
1	GND	Ground
2	RXD	Receive Data Input (from external device)
3	TXD	Transmit Data Output (to external device)
4	RTS	Ready to Send Output (to external device)

RS-232 Pins

1 2 3 4



Figure 4-2: J4 - RS-232 Jack Pinout

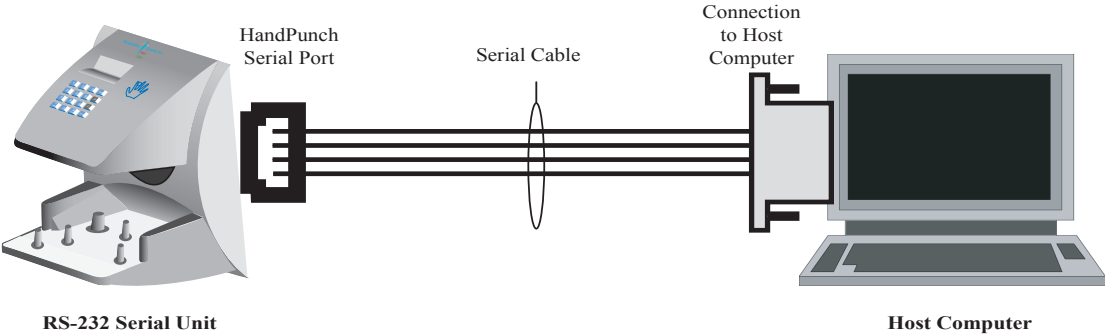

Figure 4-3: Host PC to RS-232 Connection

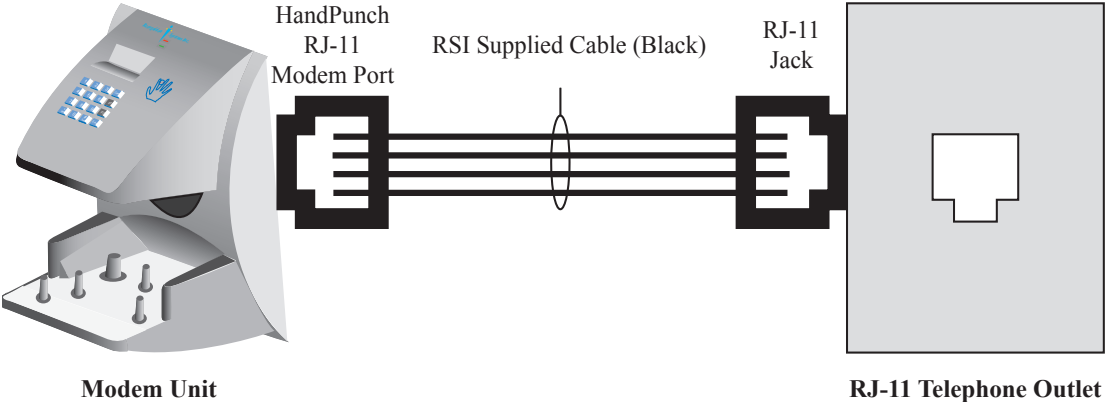

Figure 4-4: Host PC to HandPunch Modem Connection

This page is intentionally blank.

Erasing the Memory

There are two options when erasing the memory of the HandPunch.

1. Setup
2. All

The erasing of the setup will set the HandPunch's address, passwords, etc. back to factory defaults.

Choosing the All option will take the HandPunch's setup back to factory defaults plus erase all user databases and datalogs. This action can not be undone. If there is a software that is managing the system then the users can be downloaded back to the HandPunch if needed.

Erasing HandPunch Memory

The erase memory function allows a HandPunch's setup and/or user database to be erased.

Perform the following steps to erase the setup programs but retain the user database.

1. With system power OFF, depress reset switch.
2. Turn system power ON and wait 5 seconds.
3. LCD screen will display

ERASE	:1 SETUP :9 ALL!!!
--------------	-------------------------------------

This page is intentionally blank.

Closing the HandPunch

Before closing the HandPunch clear all dust and debris away from the HandPunch. With the wall mount latch in the unlocked position, swing the body of the HandPunch up and lock the latch into place with the key provided with the HandPunch (see Figure 6-1).

NOTE *Dust and debris surrounding the HandPunch can drastically affect the terminal's operation. It is important to ensure the HandPunch is free from dust and debris before closing the terminal.*

NOTE *Do not force the HandPunch onto the wall mount latch when the latch is in the locked position.*

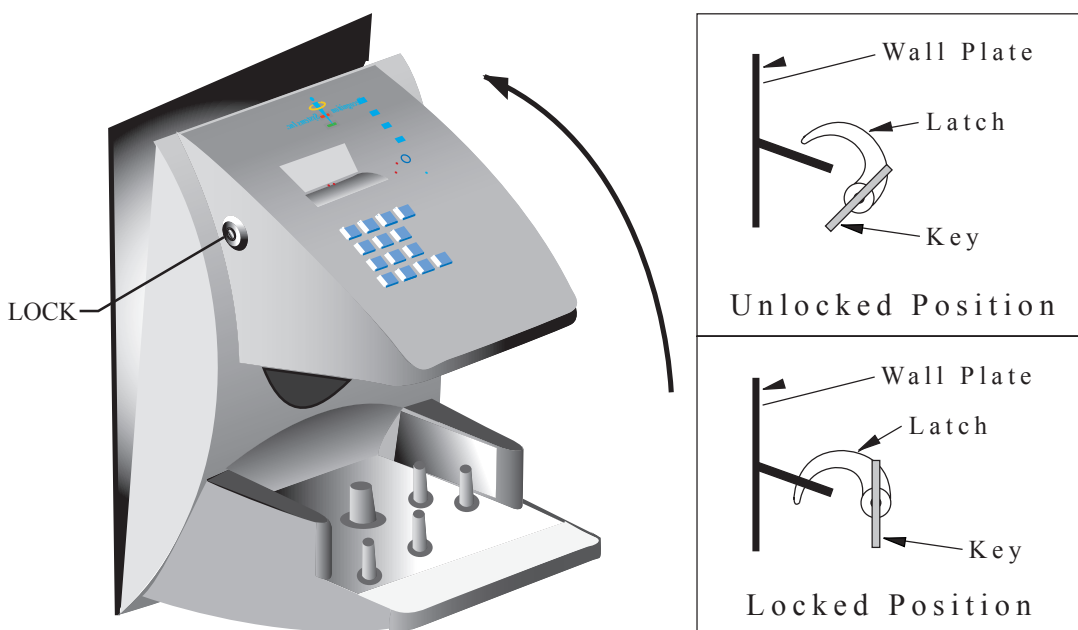

Figure 6-1: Closing the HandPunch

This page is intentionally blank.

Enter Command Menu

Press the **CLEAR** and **ENTER** keys simultaneously to enter a command menu.

If No One is Enrolled in the HandPunch

1. The display appears as follows.



2. Press the default password for the menu you wish to enter.

Press **1** for the Service Menu.

Press **2** for the Setup Menu.

Press **3** for the Management Menu.

Press **4** for the Enrollment Menu.

Press **5** for the Security Menu.

3. Press **ENTER** and the first command option in the selected menu appears.

If Users are Enrolled in the HandPunch

1. The display appears as follows.



2. Enter your ID number on the keypad and place your hand on the platen for verification.
3. If verification is successful, the display appears as follows.

ENTER PASSWORD

4. Enter the password for the menu you wish to enter. The default passwords are as follows.

Press **1** for the Service Menu.

Press **2** for the Setup Menu.

Press **3** for the Management Menu.

Press **4** for the Enrollment Menu.

Press **5** for the Security Menu.

5. Press **ENTER**.

6. If you are authorized to use this command the first command option in the selected menu appears.

7. If you are not authorized to enter this command the display appears as follows.

ENTER
*:

NOTE *To access these menus you must be the first person enrolled in a new system installation or you must have been enrolled as a supervisor. If you are blocked from the supervisory menus, verify your access rights with management personnel. If enrollment information has been incorrectly changed and you must have supervisory access to all menus, make these changes through software.*

NOTE *It is possible to physically reset the HandPunch's memory, however resetting memory sets all unit parameters back to the factory default values. Resetting memory allows access to all menus by the first person enrolled (as if it is a new system installation), but this means that **all employee information programmed into the HandPunch is lost and must be re-entered manually.** Be sure you need to reset memory before performing this function. To reset memory, refer to the Erasing HandPunch Memory section on page 21.*

**Navigating
Command
Menus**

Once you have entered a command menu, there are three options available for navigating the command menu system.

- Press **#** to enter the command shown on the display.
- Press ***** to step to the next command in the menu.
- Press **CLEAR** to exit the command menu (pressing any numeric key also exits the command menu). If you are in a command's sub-menu, you may have to press **CLEAR** multiple times to completely exit the command menu.

This page is intentionally blank.

Programming the HandPunch

The HandPunch is programmed via a series of command menus. A summary of the menus and commands is given in Table 3.

Table 3: Basic Command Mode Structure

Service Menu	Setup Menu	Management Menu	Enrollment Menu	Security Menu
Password 1	Password 2	Password 3	Password 4	Password 5
Calibrate	Set Language	List Users	Add Employee	Special Enroll
Status Display	Set Date Format	Set User Data	Add Supervisor	
	Set Time and Date		Remove User	
	Set Address			
	Set ID Length			
	Set Serial			
	Upgrade			

To control access to the command menus, each menu has a unique password. This password is requested as a part of the process for accessing each menu. A supervisor must enter the correct password for that menu to access that menu. The default menu passwords are given in Table 3.

To increase the security of the HandPunch, Recognition Systems recommends changing the passwords for the command menus to new numbers. These password numbers can be up to 10 digits long. This is done with the Set Passwords command described on.

Authority Level

A second method for controlling access to the command menus is through the use of Authority Levels. Authority Levels control whether or not a user has access to the command menus.

- Level 0 is for a user who does not need access to any of the command menus.
- Level 5 is assigned to Supervisors who need access to all of the command menus.

The HandPunch automatically assigns Authority Level 0 to users enrolled by the Add Employee command. Authority Level 5 is automatically assigned to users enrolled by the Add Supervisor command.

NOTE *Until a user has been assigned to Supervisor, every user can access every menu. Once a user has been enrolled using the Add Supervisor (designated as a supervisor), all further user authority levels are assigned. The first person enrolled should be enrolled using the Add Supervisor command. This protects the integrity of the system. Recognition Systems strongly recommends enrolling at least two users as supervisors to ensure that more than one person has the authority to access all menus and all commands.*

Programming Order

When setting up HandPunch operations there is a general programming/operations order that should be followed.

Set HandPunch Site Parameters – Set the HandPunch site parameters to meet site-specific needs and usage: change the language used by the display, set the HandPunch's address, and set the serial communication baud rate (used if you have installed a serial printer – see page 34).

Enroll Supervisory Staff – Enroll yourself and the supervisors who will have responsibility for HandPunch management. This is done through the Enrollment Menu (see Supervisor Enrollment on page 42).

NOTE *The time, date, and ID number length are normally set by the host computer. However, a supervisor can change these parameters at a HandPunch after setup information has been downloaded from the host computer.*

These tasks are done through the Setup Menu. The instructions for reader setup parameters begin on page 34.

Train and Enroll Users – Train each user regarding HandPunch usage and then Enroll each user. This is done through the Enrollment Menu. The instructions for employee enrollment begin on page 39. Special enrollment allows you to enroll people with disabilities that prevent them from using the HandPunch properly. Employees with special enrollment ID numbers can punch in without biometric verification.

WARNING *This means that anyone who knows a special enrollment ID number can punch in. This function should only be used if absolutely necessary. The instructions for special enrollment begin on page 43.*

System Management

Once a HandPunch system is in operation the following commands are used for system management.

List Users – List the Users authorized to use a HandPunch. This is done through the Management Menu. The instructions for listing employees begin on page 37.

Set User Data – Set a user's reject threshold (adjusting the sensitivity applied when a HandPunch reads a hand) this task is done through the Management Menu. The instructions for setting user data begin on page 37.

Remove User – Remove employees (and supervisors) from a HandPunch. This is done through the Enrollment Menu. The instructions for removing employees begin on page 42.

Service Menu

The Service menu commands provide information that help you determine if the HandPunch is performing within normal operating parameters and identify the status of the unit's inputs and outputs. The following section provides a brief summary of the Service Menu commands.



There are no user serviceable parts inside the HandPunch.

Navigating the Service Command Menu

Enter the appropriate password to enter the Service command menu. Once you have entered the command menu, there are three options available for navigating the command menu system.

- Press **#** to enter the command shown on the display.
- Press ***** to step to the next command in the menu.
- Press **CLEAR** to exit the command menu (pressing any numeric key also exits the command menu). If you are in a command's sub-menu, press **CLEAR** multiple times to completely exit the command menu.

Service Commands

There are two commands available from the Service command menu.

- Calibrate
- Status Display

Refer to Table 4 and identify the command you need to perform. Step through all previous commands until you reach the desired command.

Table 4: Service Command Menu

Service Menu
Password = 1
Calibrate
Recal (Y/N)
Status Display
On/Off (Y/N)

Calibrate

The Calibrate command displays the HandPunch’s exposure values, allowing you to verify these values are within normal operating parameters. The standard operating parameters are shown in Table 5.

Table 5: Normal Operating Parameters

Parameter	Normal Range
Row “r”	0 +/- 2
Column “c”	0 +/- 2
Exposure “e”	100 +/- 20

Status Display

The status display command allow you to enable or disable the displaying of the following information.

- the status values of HandPunch inputs and outputs
- the hand read score of the last user to verify on the system

When the status display is enabled, Figure 8-1 identifies each status display field value.

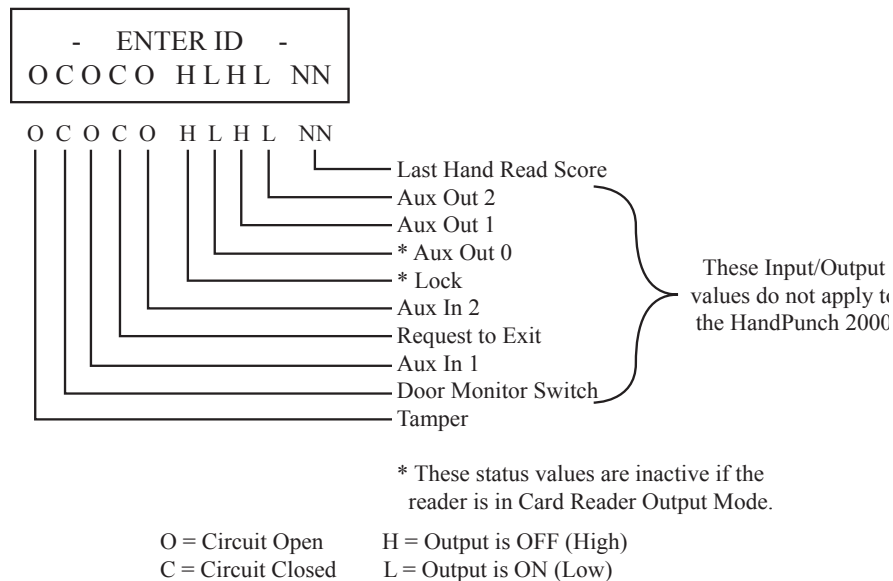

Figure 8-1 Status Display Chart

Setup Menu

The Setup menu commands allow you to set the basic operating parameters for the HandPunch unit. The following section provides a brief summary of all the parameters that may be set on a HandPunch unit.



Once in the Command Menu, you can step through and set the parameters for each command sequentially. You do not have to exit command mode after setting any individual command.

Navigating the Setup Command Menu

Enter the appropriate password to enter the Setup command menu. Once you have entered the command menu, there are three options available for navigating the command menu system.

- Press **#** to enter the command shown on the display.
- Press ***** to step to the next command in the menu.
- Press **CLEAR** to exit the command menu (pressing any numeric key also exits the command menu). If you are in a command's sub-menu, press **CLEAR** multiple times to completely exit the command menu.

Setup Commands

There are six commands available from the Setup command menu.

- Set Language
- Set Date Format
- Set Date and Time
- Set Address
- Set ID Length
- Set Serial

Refer to Table 6 on page 35 and identify the command you need to perform. Step through all previous commands until you reach the desired command.

Table 6: Setup Command Menu

Setup Menu
Password = 2
Set Language
Select Language
Set Date Format
Select Date Format
Set Time and Date
Month (MM)
Day (DD)
Year (YY)
Hour (HH)
Minute (MM)
Set Address
New Address
Set ID Length
New ID Length
Set T & A Mode
Set Serial ^a
RS-232
Select Baud Rate
Upgrade
Code

a.

Set Language The Set Language command allows the language shown on the HandPunch's display to be "localized" for a variety of countries.

- English
- Japanese
- French
- Italian
- Spanish
- German
- Russian
- Indonesian
- Portuguese
- Polish

Set Date Format The Set Date Format command allows the date format shown on the HandPunch's display to be "localized" for a variety of countries.

- mm/dd/yy
- dd-MMM-yy
- dd-mm-yy
- dd/mm/yy
- mm-dd-yy
- MMM dd,yy
- ddMMMyyyy

Set Time and Date The Set Time and Date command allows the HandPunch's time and date to be set. This is normally not necessary as the HandPunch's time and date are set by the host computer.

Set Address The Set Address command allows a unique address to be set for each HandPunch in a network. For proper operation, each HandPunch in the network must have a unique address. All units may use any address from 0 to 254. All units are sent with the address set to 1.

Set ID Length The Set ID Length command allows you to reduce the number of keystrokes required to enter the ID number by eliminating the use of the **ENTER** key to complete an ID number entry. Once the ID Length is set, the HandPunch will automatically accept an ID number entry once the correct number of characters have been entered.

Set ID Length does not apply when ID entry is made from a card reader. Once the ID Length is set, the T & A Mode Set command appears, allowing you to configure the HandPunch to prepare punch data for time and attendance software.

Set Serial The Set Serial command allows you to set the baud rate communication parameters.

Upgrade This Upgrade Menu is where the HandPunch code gets input to allow for a Memory Upgrade.

Management Menu

The Management menu commands allow you to manage employee data stored in a HandPunch unit. The following section provides a brief summary of the employee data that may be manipulated on a HandPunch unit.

Navigating the Setup Command Menu

Enter the appropriate password to enter the Setup command menu. Once you have entered the command menu, there are three options available for navigating the command menu system.

- Press **#** to enter the command shown on the display.
- Press ***** to step to the next command in the menu.
- Press **CLEAR** to exit the command menu (pressing any numeric key also exits the command menu). If you are in a command's sub-menu, press **CLEAR** multiple times to completely exit the command menu.

Management Commands

There are four commands available from the Management command menu.

- List Users
- Set User Data

Refer to Table 7 and identify the command you need to perform. Step through all previous commands until you reach the desired command.

Table 7: Setup Command Menu

Setup Menu
Password = 3
List Users
Display
Print
Set User Data
User Reject

- List Users** The List Users command allows you to display or print a list of all the employees enrolled in a HandPunch.
- Set User Data** The Set User Data command allows you to set an employee's Reject Threshold, adjusting the hand read threshold for one employee without affecting the threshold of other employees. This task should be done through your user software, however it can be done through the Management Menu.

Enrollment Menu

Enrollment is the process of recording a hand image and associating it with an ID number. The first person to enroll in the HandPunch has access to all command menus. This person should enroll using the Add Supervisor command (see page 42). Once a supervisor has been enrolled, all further enrollments use the following rules:

- A user enrolled through the Add Employee command (page 42) is assigned Authority Level 0. This allows the user to punch in and/or gain access through a door secured by the HandPunch.
- A user enrolled through the Add Supervisor command (see page 42) is assigned Authority Level 5. This allows the supervisor to punch in and gain access through a door secured by the HandPunch, and it allows the supervisor to access all command menus.



NOTE *Until a user has been assigned to Authority Level 5 using the Add Supervisor command, every user with Authority Level 0 can access every menu. This is done to ensure that the first person enrolled is able to access all the menus to perform all the programming required to support the HandPunch. Once a user has been enrolled using the Add Supervisor command, all further user authority levels are assigned as per the list above. This protects the integrity of the system by enacting the Authority Level rules described above. Recognition Systems strongly recommends enrolling at least two users as supervisors to ensure that more than one person has the authority to access all menus and all commands.*

Advance planning and training make enrollment fast and easy. Users should be informed on what to expect and how to place their hands on the HandPunch before you enroll them.

Navigating the Setup Command Menu

Enter the appropriate password to enter the Setup command menu. Once you have entered the command menu, there are three options available for navigating the command menu system.

- Press **#** to enter the command shown on the display.
- Press ***** to step to the next command in the menu.
- Press **CLEAR** to exit the command menu (pressing any numeric key also exits the command menu). If you are in a command's sub-menu, press **CLEAR** multiple times to completely exit the command menu.

Preparation

Here are a few guidelines to help you prepare for an enrollment session.

- You can enroll one person or a group of people during an enrollment session.
- Each user must have a unique personal identification (ID) number. It will save you considerable time if you assign the ID numbers in advance.
- The HandPunch will not accept two people with the same ID number.
- If you enroll people using the last four digits of their phone numbers or social security numbers, you may get duplicate numbers.
- If you are enrolling large groups of people you may consider using an enrollment trainer. It is a replica of a platen that is available through your Recognition Systems reseller.

User Education

The HandPunch is easy to use and non-threatening. However, most people have never used a biometric HandPunch. Training users on how the HandPunch works and how to use it will eliminate most fears and concerns before they occur. Inform the users of these facts.

- The HandPunch reads the shape of the hand, not the fingerprints or palmprints.
- It does not identify people. It confirms people's identity.
- It scans with an invisible light of the type used in TV remote controls.
- It does not transfer germs any more than a doorknob or money.
- It does not invade privacy; it guarantees it.
- The enrollment process requires three or more reads to collect enough information to create a template.

Proper Hand Placement

For correct, consistent hand reads it is very important that your hand is placed on the platen in the same manner every time. The following rules apply for proper hand placement on the platen also refer to Figure 8-2 bellow.

- If you are wearing a ring, rotate the ring so the stone faces up in its normal position.
- Slide your right hand onto the platen rather like an airplane landing at the airport.
- Slide your hand forward until the web between your index and middle finger stops against the Web Pin.
- Keep your hand flat. You should feel the surface of the platen on your palm and the underside of your fingers.
- Close your fingers together until they touch the Finger Pins and watch the hand diagram light display on the top panel.
- The lights go out when you have properly placed your fingers. If a light remains on, a finger is not in proper contact with its Finger Pin.



Figure 8-2: Placing Your Hand on the Platen

Left Hand Enrollment

Some right hands cannot be used in the HandPunch due to disabilities such as missing fingers. You can enroll a user with the left hand facing palm side up. The techniques for left hand enrollment are the same as for standard enrollment. The user should keep the back of the hand flat against the platen and move the fingers against the web pin and the finger pins in the same manner as in standard enrollment. Users enrolled with the left hand must always verify with the left hand. Extra practice on placing the hand on the platen may be required to ensure correct, consistent hand reads.

Read Score

When a user uses the HandPunch the display appears as follows.

**OKAY (USER ID)
SCORE IS: (SCORE NUMBER)**

The score number on the display reflects how accurately the user's hand is placed on the platen. Scores that vary greatly between low and high numbers are indicative of inconsistent hand placement. Scores above 50 are indicative of improper hand placement or of a drastic change in the physical appearance of the hand.

When this occurs, emphasize the importance of sliding the hand onto the platen and keeping the hand flat. Re-training and practice should lower a user's score. It might be necessary to change a user's reject threshold if the user has a mild disability. Re-enrollment might be necessary to create a new user template.

**Enrollment
Commands**

There are three commands available from the Enrollment command menu.

- Add Employee
- Add Supervisor
- Remove User

Refer to Table 12 to identify the command you need to perform. Step through all previous commands until you reach the desired command.

Table 8: Enrollment Command Menu

Service Menu
Password = 4
Add Employee
ID #
Add Supervisor
ID #
Remove User
ID #

Add Employee

The Add Employee command allows you to enroll a new employee into the HandPunch.

**Add
Supervisor**

The Add Supervisor command allows you to enroll a new supervisor into the HandPunch.

Remove User

The Remove User command allows you to remove an employee or supervisor from the HandPunch.

Special Menu

The Special menu has one command – Special Enroll. This command accommodates users with disabilities that make it difficult or impossible to use a HandPunch in its standard way. The following section provides a brief description of the Special Menu command.

Navigating the Special Command Menu

Enter the appropriate password to enter the Special command menu. Once you have entered the command menu, there are three options available for navigating the command menu system.

- Press **#** to enter the command shown on the display.
- Press ***** to step to the next command in the menu.
- Press **CLEAR** to exit the command menu (pressing any numeric key also exits the command menu). If you are in a command's sub-menu, press **CLEAR** multiple times to completely exit the command menu.

Special Command

There is one command available from the Special command menu.

- Special Enroll

Refer to Table 9 and identify the command you need to perform. Step through all previous commands until you reach the desired command.

Table 9: Special Command Menu

Special Menu
Password = 5
Special Enroll
ID #
On/Off (Y/N)

Special Enroll

The Special Enroll command allows a user to be enrolled such that the ID number is the primary criteria for determining access. A hand read is required,

but is not verified against any stored identification data. A time zone value can be applied to the Special Enrollment ID number to limit access times. The HandPunch default is for no time zone to be applied.



Special Enrollment affects the integrity of the HandPunch terminal and should only be used as a last resort. Anyone who knows a Special Enroll ID number is granted access when the ID number is used. Before specially enrolling a user, try to alleviate verification problems by adjusting the individual user's reject threshold (see page 38) or by using left hand enrollment (see page 41).

HandPunch Maintenance

A minimum amount of system maintenance is required to keep HandPunches fully functional. HandPunches should be cleaned periodically to prevent an accumulation of dust from affecting the HandPunch's readability. User Scores should be reviewed periodically to ensure the HandPunch is performing properly.

NOTE *There are **NO** user serviceable parts inside the HandPunch.*

Once a HandPunch system is in operation there are two HandPunch commands that can assist with system maintenance. These commands are performed through the Service Menu. The instructions for these commands begin on page 32.

- Calibrate – View HandPunch exposure values.
- Status Display – Display HandPunch input/output status, the hand read score of the last user to verify on the system.

Cleaning the HandPunch

Inspect and clean the HandPunch regularly to maintain optimum performance. Clean the platen, side mirror, reflector, and the window above the platen using a clean cloth dampened with ordinary, non-abrasive window cleaner (see Figure 9-1). Start at the rear corners of the platen and work your way forward.

NOTE *DO NOT SPRAY CLEANING FLUID DIRECTLY INTO OR ON THE HandPunch.*

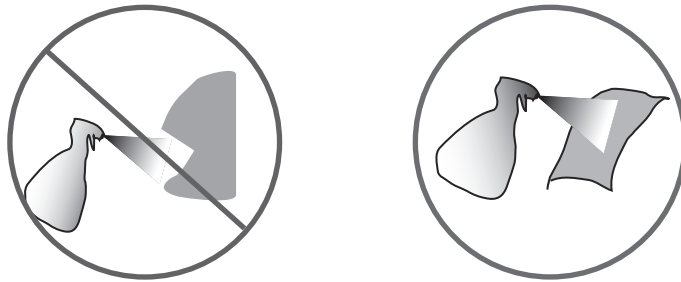

Figure 9-1: HandPunch Cleaning

User Score

Periodically check users' scores (refer to the Read Score section on page 41). Scores should average under 30. Occasionally a user will score above 30. This is not necessarily an indication of poor performance. If a number of scores average over 30, clean the HandPunch and check scores again. If scores remain high, or if users are experiencing frequent rejections, run the Calibration command (see page 32).

This page is intentionally blank.

Appendix A

Tips for a successful Installation

HandPunch

- Think of the HandPunch as a camera
- Clean the HandPunch before it gets dirty
- Use non-abrasive cleaners such as glass cleaners and non-abrasive and clean cloths
- Make cleaning the HandPunch part of Janitorial program
- Do not remove the foam backing from the wall mounting plate
- Seal any holes made in the wall for wire routing, so that dust will not blow into the HandPunch

Location

- Mount all HandPunchs in a network so that the top of the platen is 40” off of the floor
- If an enrollment HandPunch is used make sure that it is placed with the top platen 40” off of the floor and not sitting directly on top of a desk, this will help to eliminate “bad enrollments”
- Mount the HandPunch so that it is not difficult or dangerous to verify then open the door
- It is not recommended to mount the HandPunch in an area where there is airborne dust, in the path of direct sunlight, or where the HandPunch can be exposed to water or corrosive gasses

Enrollment

- Educate the Enrollee on Hand Geometry
- Explain enrollment process
- Train Enrollee on hand placement
 - Practice placing hand on platen
 - Make sure hand is flat on platen
 - Close finger towards the center of hand
 - Fingers gently touch finger pins
- Let the enrollee enter in their own ID number during the enrollment process, this forces the Enroller to step aside allowing the Enrollee to stand in front of the HandPunch helping to eliminate “bad enrollments”

This page is intentionally blank.

Appendix B

Noted Board Configuration Differences

Because of Recognition Systems' camera retrofit of the HandPunch some changes have been made to the main PCB and they are listed as follows:

- Dipswitches have been removed
-memory is reset with a push-button reset and user interface with keypad and LCD
- Power has moved to the right side of the PCB
- The RS-232 RJ-45 receptacle has been replaced with a 4 pin Molex connector on the left side of the PCB
- A 2 pin Molex connector (J5) has been added to the board, next to the reset button, to supply power for the LEDs. This connector should never be unplugged. unless a modem or Ethernet is added to the PCB
- The upgrading of the memory is now handled through software codes at the HandPunch. Contact Order Entry for memory upgrades

Memory Reset

To reset the memory of the HandPunch follow these steps-

1. Remove power and battery jumper, if a back up battery is installed
2. Press down on reset button and apply power
3. Release button
4. Reader will boot to

ERASE	:1 SETUP
	:9 ALL!!!

- Press 1 to erase setup i.e. address, outputs, passwords, but retain user database and datalogs
- Press 9 to erase everything i.e. HandPunch goes back to factory defaults

This page is intentionally blank.

Mechanical Installation

Select an installation location based on the guidelines provided in the [Planning an Installation](#) section beginning on page 9.

Wall Plate Installation

Wall Preparation

NOTE For the following procedure protect the HandPunch from the dust and debris generated during the wall plate installation process.

1. Remove the wall plate from the packing carton. Refer to Figure 12-1 for all wall plate references in the following section.

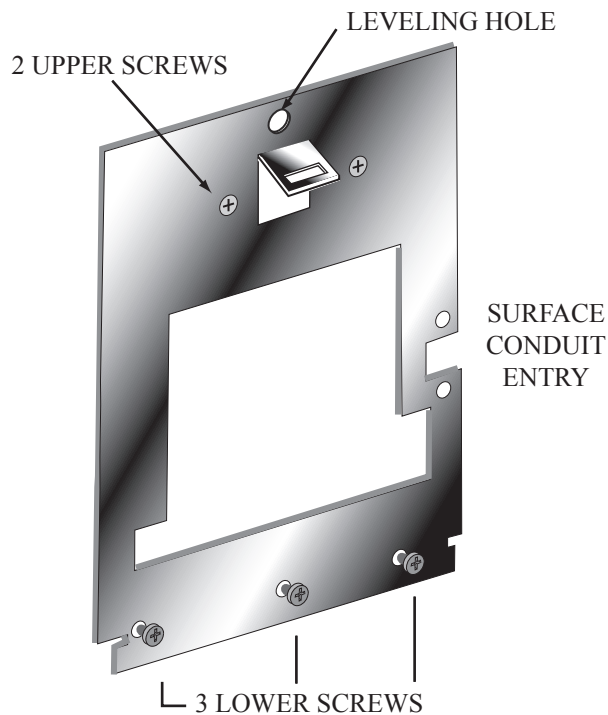

Figure 12-1: Wall Plate

2. Measure and mark a point 48 1/2 inches (123 cm) from the surface of the finished floor. This point will correspond to the Leveling Hole where the top-center point of the HandPunch should be mounted.
3. For a hollow wall, drive a small nail into the wall at the mark and hang the wall plate from the Leveling Hole located near the top of the wall plate.
4. For a solid wall, hold the wall plate against the wall, centering the Leveling Hole over the mark in the wall.

5. Align a bubble level with the top edge of the wall plate and gently rotate the wall plate until the bubble level shows that the top edge of the wall plate is level.
6. Secure the plate to the wall using heavy masking tape.
7. Using the wall plate as a template, mark the locations of the two upper screw holes and the three lower screw holes.
8. For a concealed wiring connection, trace the outline of the open area in the center of the wall plate. Identify and mark a 1/2 inch hole through which the HandPunch's wiring will be mounted.
9. For a surface conduit wiring connection, mark the two conduit clamp holes at the right side of the wall plate.
10. Remove the wall plate, masking tape, and the nail (if used).

Mounting the Wall Plate

1. For a hollow wall, use the provided hardware to mount the wall plate. Use the two auger style fasteners for the upper two mounting holes. Use the toggle bolts for the three lower mounting holes.
2. For a solid wall, use expansion bolts to mount the wall plate. For all five mounting holes, drill a 1/4 inch diameter hole, 1/4 of an inch deeper than the length of the expansion anchor.

Routing the Wiring

1. Refer to Figure 12-2 on page 52 for a template diagram to assist in routing wiring.
2. For a concealed wiring connection, drill a 1/2 inch hole in a convenient location within the open area of the wall plate. Pull the wiring to enter the HandPunch through this hole in the open area.
3. For a surface conduit wiring connection, drill a 1/4 inch diameter hole, 1/4 of an inch deeper than the length of the expansion anchor for each of the two conduit clamp holes. Route 1/2 inch, flexible conduit to the HandPunch, ending the conduit between the two conduit clamp holes. Pull the wiring to enter the HandPunch through the conduit. Pull 18 inches of wire past the end of the conduit to allow enough space for final connection to the HandPunch.
4. Clear all dust and debris away from the HandPunch mounting location.

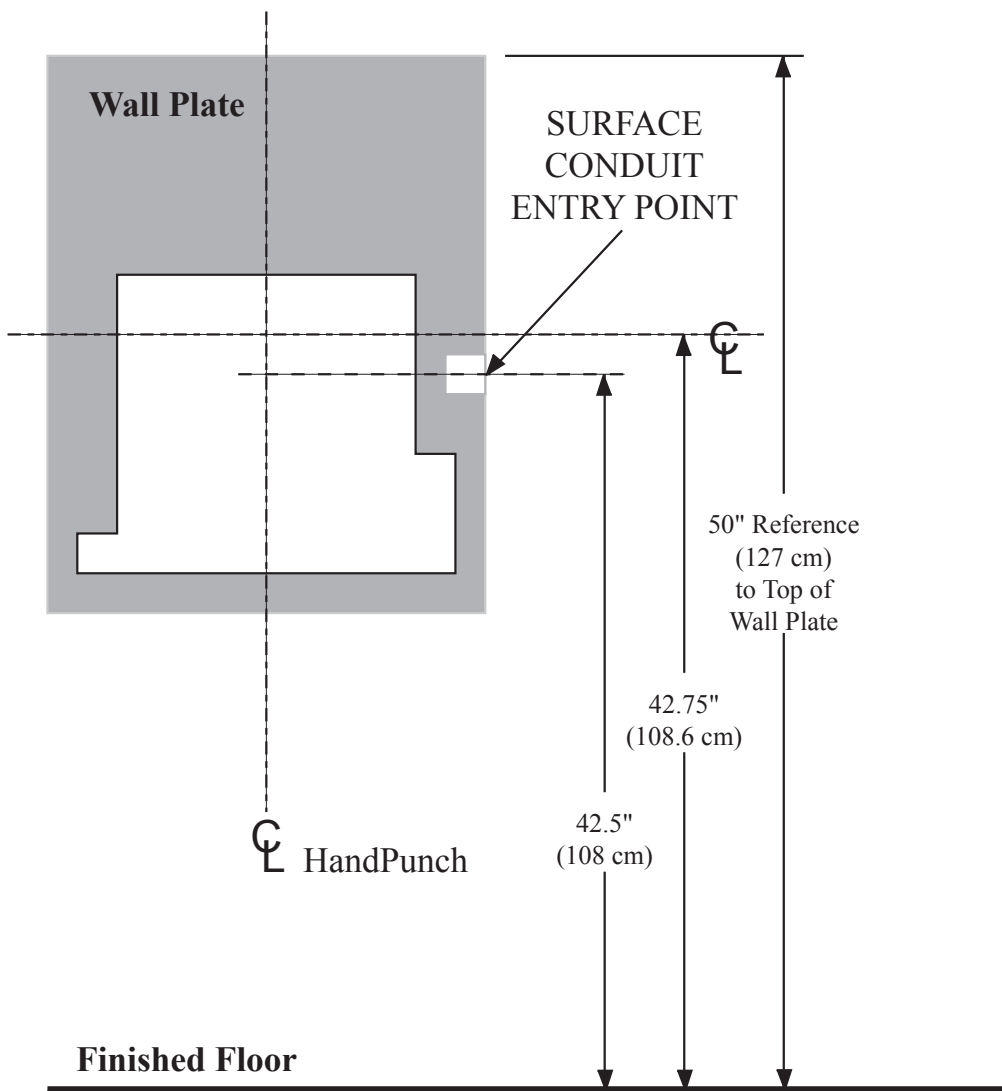

Figure 12-2: HandPunch Wire Routing Layout

NOTE *Dust and debris surrounding the HandPunch can drastically affect the terminal's operation. It is important to ensure the HandPunch mounting location is free from dust and debris.*

Attaching the HandPunch

1. Loosen the three bottom mounting screws until there is approximately 1/8 inch (3 mm) clearance between the screw head and the wall plate.
2. Remove the HandPunch from its carton.
3. At the base of the HandPunch is a piano hinge with three keyhole shaped slots that correspond with the three lower mounting screws. Align and hang the HandPunch from the three lower mounting screws (see Figure 12-3 on page 54).
4. Tighten all three lower mounting screws.
5. The HandPunch is now ready for its wiring connections.

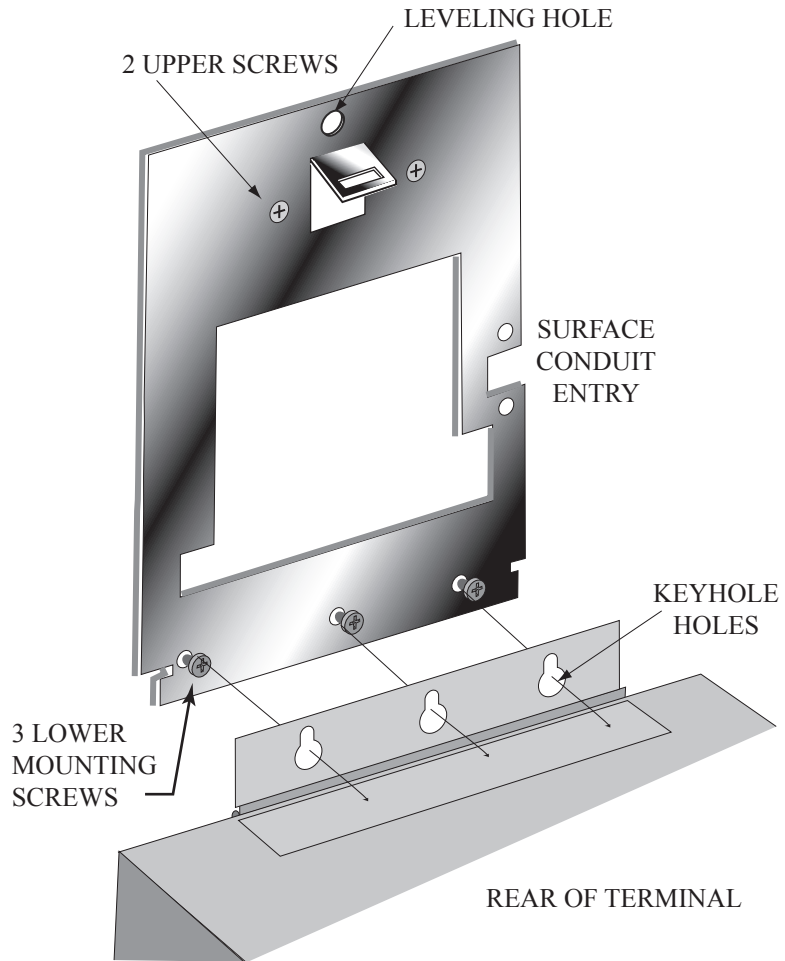

Figure 12-3: Attaching the HandPunch to the Wall Plate

Wiring Connections

Once the HandPunch is attached to the wall plate the wiring connections to the HandPunch can be made (see Figure 12-4).

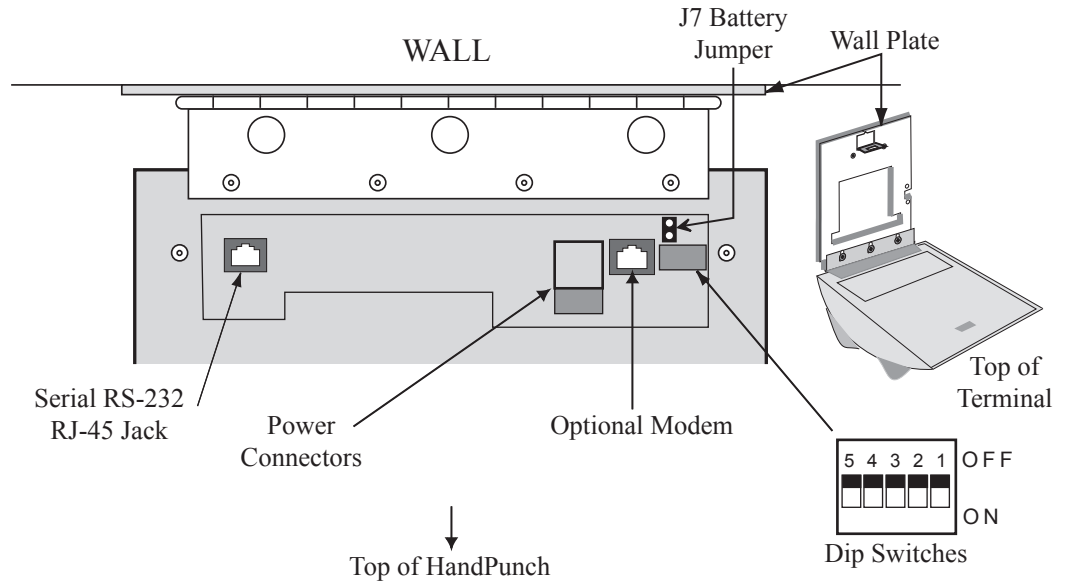

Figure 12-4: Wiring Connections and Dip Switches

Wiring Examples

Table 10 on page 56 provides the pinouts for the RJ-45/RS-232 Serial Host Computer Connection.

Figure 12-5 on page 56 provides a diagram of the RJ-45/RS-232 Connector.

Figure 12-7 on page 57 provides a Host PC to HandPunch Modem Network wiring diagram (Modem wiring is a HandPunch option).

Table 10: RJ-45/RS-232 Serial Connection

J8 Pin	Signal	Connection
1	RI	- not used -
2	CD	- not used -
3	DTR	- not used -
4	GND	Ground
5	Rx Data	Receive Data Input (from external device)
6	Tx Data	Transmit Data Output (to external device)
7	CTS	- not used -
8	RTS	- not used -

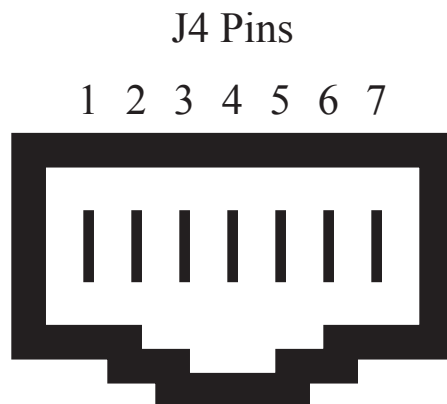

Figure 12-5: J4 - RJ-45/RS-232 Jack Pinout

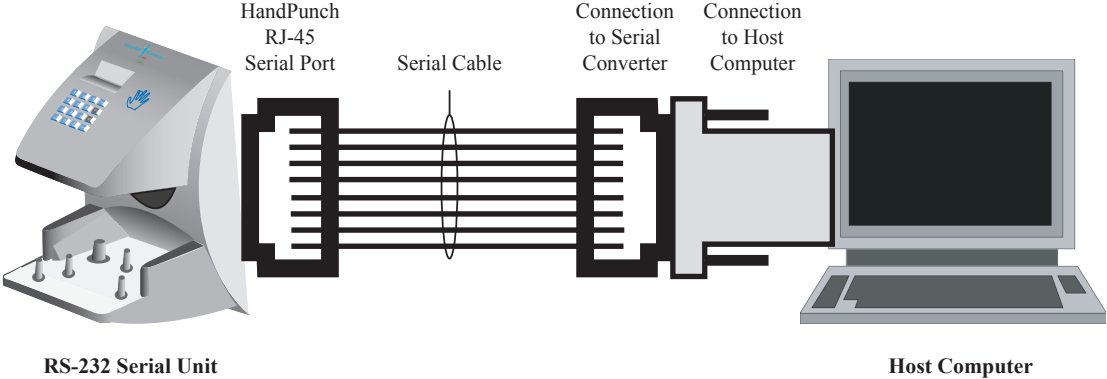

Figure 12-6: Host PC to RS-232 Connection

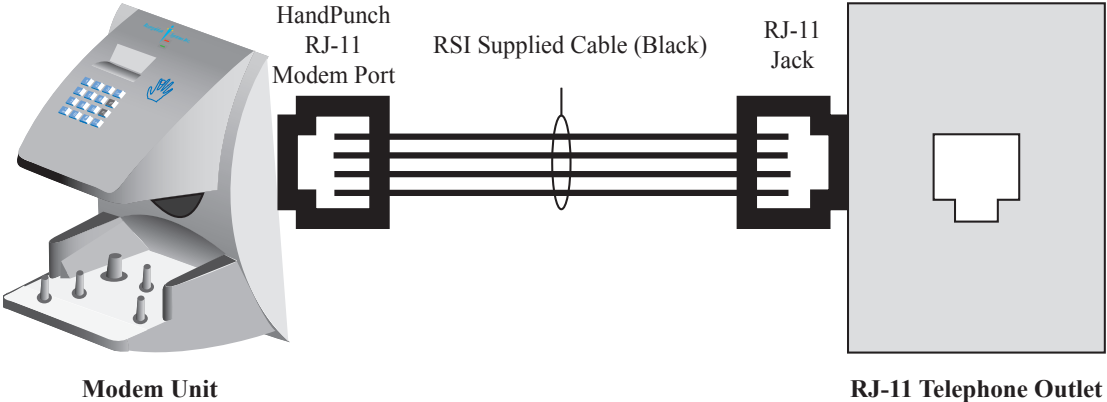

Figure 12-7: Host PC to HandPunch Modem Connection

Setting the DIP Switches

The DIP Switch settings perform three tasks for the HandPunch (see Figure 12-8).

- Set End of Line (EOL) Termination to match the type of termination needed by the network.
- Set the Communication Method to match the type of network used.
- Erase Memory to clear HandPunch memory to all factory default values and also clear all user memory.

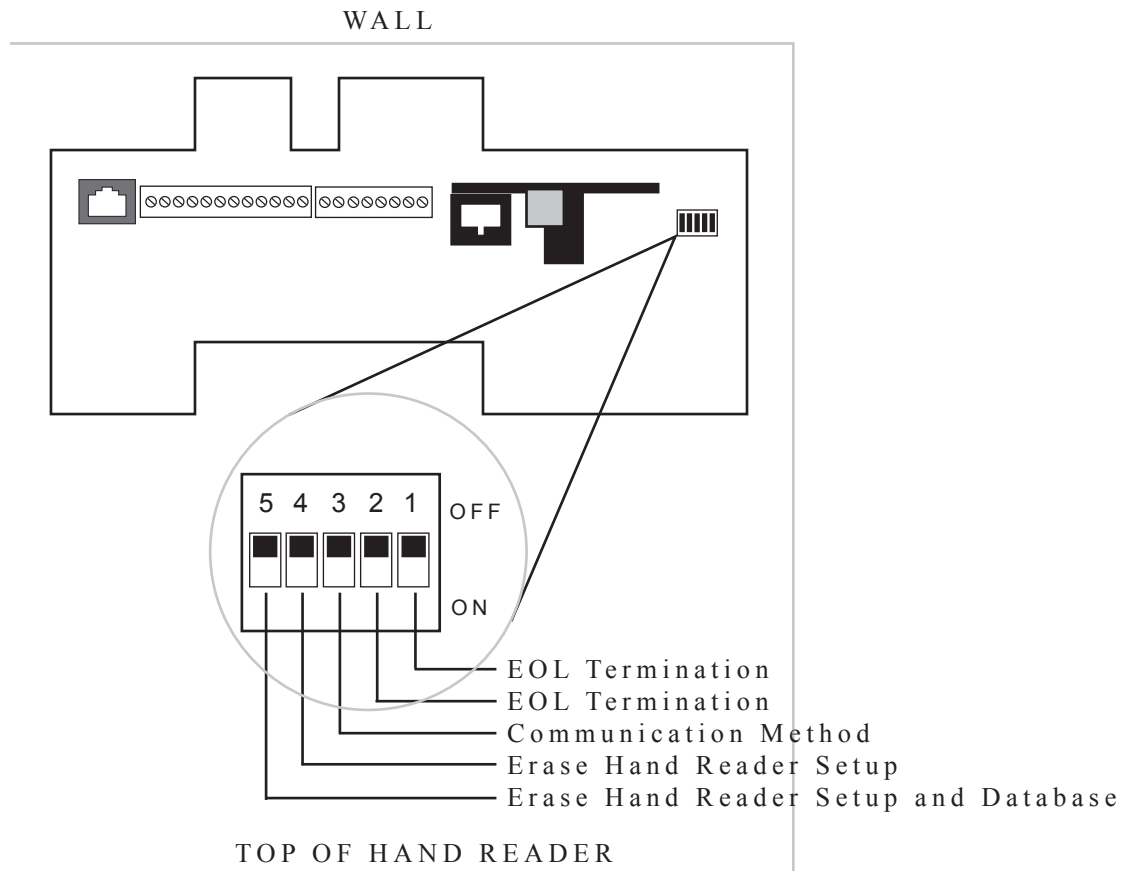

Figure 12-8: HandPunch Dip Switches

End of Line Termination

Termination helps to ensure clean data signals are transmitted through the network wiring. Termination is applied to the end-of-line (EOL) HandPunch in the network daisy-chain. The factory default setting is for EOL termination to be disabled – switches 1 and 2 OFF. Refer to Figure 12-8 on page 58 for switch ON/OFF positioning.

- To enable EOL termination at a HandPunch, both switches 1 and 2 must be ON.
- To disable EOL termination at a HandPunch, both switches 1 and 2 must be OFF.

EOL Termination must be **enabled** for:

- A single HandPunch terminal installation.
- In a Modem to PC network the HandPunch terminal with the Modem option (for communication with the host computer).

Communication Method

The factory default setting and for standard operation, switch 3 must be OFF.

- Switch 3 must always be OFF.

Erasing HandPunch Memory

The erase memory function can perform either or both of the following:

- Erase a HandPunch's configuration data.
- Erase a HandPunch's user database and transaction buffer.

The factory default setting (and normal operation setting) is for switches 4 and 5 to be OFF, retaining memory.

**NOTE**

If the HandPunch is equipped with the battery backup option, remove shunt J7 in front of the DIP switch array (see Figure 12-4 on page 55) before proceeding. Replace shunt J7 after completion of the following steps.

Erasing the HandPunch Setup

Perform the following steps to erase the configuration data but retain the user database.

1. With system power OFF, set switch 4 ON.
2. Turn system power ON and wait for HandPunch boot information to appear on the display.
3. Turn switch 4 OFF.

Erasing the HandPunch Setup and User Database

Perform the following steps to erase both the configuration data and the user database.

1. With system power OFF, set both switches 4 and 5 ON.
2. Turn system power ON and wait 5 seconds.
3. Turn both switches 4 and 5 OFF.



Before putting the HandPunch into service ensure DIP switches 4 and 5 are both OFF. If switches 4 and 5 are not off, the next time the HandPunch's power is cycled the HandPunch's memory will be erased.

Closing the HandPunch

Before closing the HandPunch, ensure dip switches 4 and 5 are OFF (refer to Figure 12-8 on page 58). Clear all dust and debris away from the HandPunch. With the wall mount latch in the unlocked position, swing the body of the HandPunch up and lock the latch into place with the key provided with the HandPunch (see Figure 12-9).

NOTE *Dust and debris surrounding the HandPunch can drastically affect the terminal's operation. It is important to ensure the HandPunch is free from dust and debris before closing the terminal.*

NOTE *Do not force the HandPunch onto the wall mount latch when the latch is in the locked position.*

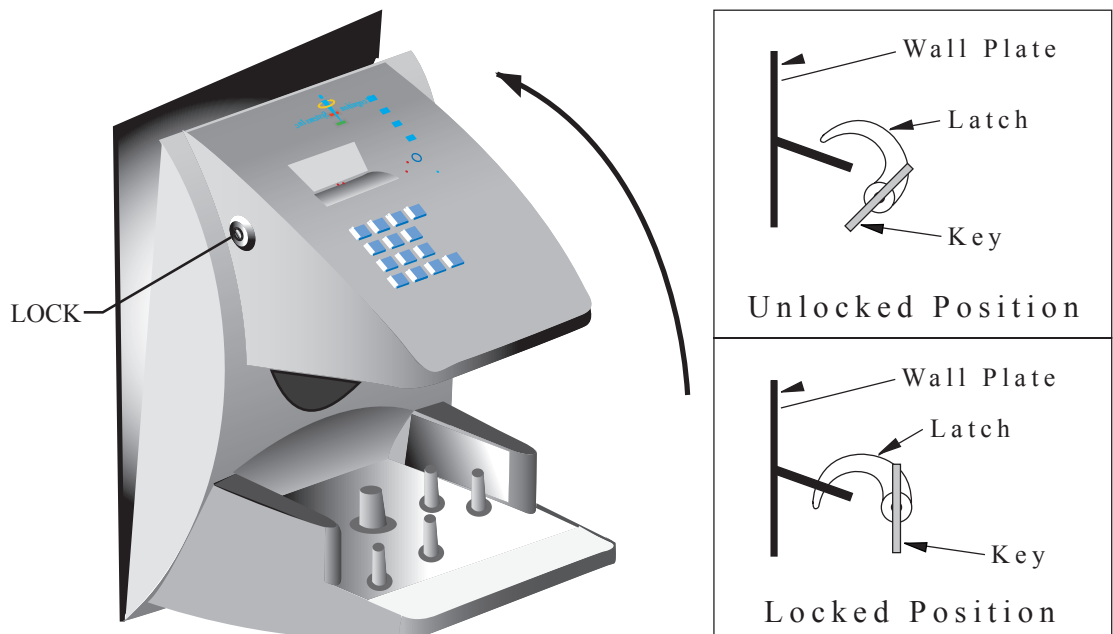

Figure 12-9: Closing the HandPunch

This page is intentionally blank.

Appendix D

Troubleshooting Guide

Display Messages During Verification

Various messages can appear on the HandPunch's display during hand verification. These messages are defined in Table 18.

Table 11: Display Messages During Verification

Message	Definition
PLACE HAND	The platen is ready to receive your hand for verification.
ID VERIFIED	You are verified, proceed.
REMOVE HAND	Remove your hand and place it on the platen again. Follow proper hand placement rules.
TRY AGAIN	Your attempt was rejected. Repeat verification following proper hand placement rules.
ID REFUSED	Your rejections exceeded the maximum number of tries allowed. Wait until another employee has verified and try again or call your supervisor.
ENTER ID	You entered your ID number incorrectly or your access time is restricted.

- If the display shows **TRY AGAIN**, you are not verified. You may have made an error in entering your ID number or in placing your hand on the platen. Re-enter your ID number and try again, taking care to follow proper hand placement rules (see page 60).
- If the display shows **TIME RESTRICTION**, you are not authorized to punch in at this time. If this seems to be in error, contact your supervisor about time restrictions.
- After a pre-programmed number of denied attempts, an ID number will no longer be accepted and the display will appear as follows.

**ID INVALID
TEMPORARILY**

This is called a “lockout.” Before the rejected ID number can be used again, another employee or a supervisor must successfully verify at the Hand-Punch.

- If you enter your ID number, but do not place your hand on the platen, the HandPunch will time-out in about 25 seconds. You can immediately end this time-out by pressing the **CLEAR** key.

Beeper and LED Status During Verification

The HandPunch’s beeper and LED status display also display hand verification information. This information is defined in Table 19.

Table 12: Beeper and LED Status During Verification

Operation	Beeps	LED	Meaning
During Keypad Entry	1 per Keystroke	–	Keystroke Accepted
After ID Entry	–	–	OK - Proceed
After ID Entry	2	–	ID Number Not in Database
After Hand Placement	1	Green	ID Verified
After Hand Placement	2	Red	ID Not Verified - Try Again
After Hand Placement	1 Long Continuous	Red	ID Refused

Glossary

Address, HandPunch – A HandPunch Address is a unique identification number assigned to a HandPunch. Each HandPunch on a network must be assigned a unique address.

AWG – American Wire Gauge is a U.S. standard set of wire conductor sizes. The “gauge” refers to the diameter of the wire. The higher the gauge number, the smaller the diameter, the thinner the wire, and the greater the electrical resistance. Thicker, smaller gauge wire carries more current because it has less electrical resistance over a given length. Thicker wire is better for long wire distances.

HandPunch Address – see Address, HandPunch

Platen – The Platen is the flat surface at the base of the HandPunch, on which a user places his/her hand for enrollment and verification. The platen has guide pins to ensure the user’s fingers are consistently positioned correctly.

Template – A Template is a set of data generated for a user. It is made up of the user’s enrollment information and any system configuration parameters that are assigned to the user. The template is stored at each HandPunch and can be stored at the host computer with the Time and Attendance software.

Transaction – A Transaction is any kind of event recorded at a HandPunch. Transactions may include In or Out punches, department transfers, and supervisor edits.

This page is intentionally blank.

Limited Warranty

Recognition Systems, Inc. (the "Company") warrants to the original user the products manufactured by the Company (the "Product") to be free of defects in material and workmanship for a period of three months from the date of purchase by such user or six months from the date of shipment from the factory, whichever is sooner, provided:

1. The Company has been notified within such period by return of any alleged defective product, free and clear of all liens and encumbrances, to the Company or its authorized dealer, transportation prepaid; and
2. The Product has not been abused, misused, or improperly maintained and/or repaired during such period; and
3. Such defect has not been caused by ordinary wear and tear; and
4. Such defect is not the result of voltage surges/brownouts, lightning, water damage/flooding, fire, explosion, earthquakes, tornadoes, acts of aggression/war, or similar phenomenon; and
5. Accessories used as integral to the Product have been approved by the Company.

The Company shall, at its option, either repair or replace, free of charge, the Product found, upon the Company's inspection, to be so defective, or if agreed upon, refund the purchase price, less a reasonable allowance for depreciation, in exchange for the Product.

THE COMPANY MAKES NO OTHER WARRANTY AND ALL IMPLIED WARRANTIES INCLUDING ANY WARRANTY OF MERCHANTABILITY OR FITNESS FOR A PARTICULAR PURPOSE ARE LIMITED TO THE DURATION OF THE EXPRESSED WARRANTY PERIOD AS SET FORTH ABOVE.

THE COMPANY'S MAXIMUM LIABILITY THEREUNDER IS LIMITED TO THE PURCHASE PRICE OF THE PRODUCT. IN NO EVENT SHALL THE COMPANY BE LIABLE FOR ANY CONSEQUENTIAL, INDIRECT, INCIDENTAL, OR SPECIAL DAMAGES OF ANY NATURE ARISING FROM THE SAME OR THE USE OF THE PRODUCT.

Recognition Systems Inc. reserves the right to make changes in the design of any of its products without incurring any obligation to make the same change on units previously purchased.

This page is intentionally left blank.